

### C3 Flexural Members

#### C3.1 Bending

The nominal flexural strength [moment resistance],  $M_n$ , shall be the smallest of the values calculated for the limit states of yielding, lateral-torsional buckling and distortional buckling. This document presents only the yielding limit state design provisions

##### C3.1.1 Nominal Section Strength [Resistance]

*Specification* Section C3.1.1 includes two design procedures for calculating the nominal section strength [resistance] of flexural members.

The nominal moment,  $M_n$ , of the cross section is the effective yield moment,  $M_y$ , determined on the basis of the effective areas of flanges and the beam web. The effective width of the compression flange and the effective depth of the web can be computed from the design equations given in Chapter B of the Specification.

Similar to the design of hot-rolled steel shapes, the yield moment  $M_y$  of a cold-formed steel beam is defined as the moment at which an outer fiber (tension, compression, or both) first attains the yield point of the steel. This is the maximum bending capacity to be used in elastic design. Figure C-C3.1.1-1 shows several types of stress distributions for yield moment based on different locations of the neutral axis. For balanced sections (Figure C-C3.1.1-1(a)) the outer fibers in the compression and tension flanges reach the yield point at the same time. However, if the neutral axis is eccentrically located, as shown in Figures C-C3.1.1-1(b) and (c), the initial yielding takes place in the tension flange for case (b) and in the compression flange for case (c).

Accordingly, the nominal section strength [resistance] for *initiation of yielding* is calculated by using Equation C-C3.1.1-1:

$$M_n = S_e F_y \quad (\text{C-C3.1.1-1})$$

where

$F_y$  = design yield stress

$S_e$  = elastic section modulus of the effective section calculated with the extreme compression or tension fiber at  $F_y$ .

For cold-formed steel design,  $S_e$  is usually computed by using one of the following two cases:

1. If the neutral axis is closer to the tension than to the compression flange, the maximum stress occurs in the compression flange, and therefore the plate slenderness ratio  $\lambda$  and the effective width of the compression flange are determined by the  $w/t$  ratio and  $f = F_y$ . Of course, this procedure is also applicable to those beams for which the neutral axis is located at the mid-depth of the section.
2. If the neutral axis is closer to the compression than to the tension flange, the maximum stress of  $F_y$  occurs in the tension flange. The stress in the

compression flange depends on the location of the neutral axis, which is determined by the effective area of the section. The latter cannot be determined unless the compressive stress is known. The closed-form solution of this type of design is possible but would be a very tedious and complex procedure. It is therefore customary to determine the sectional properties of the section by successive approximation.

For determining the design flexural strength [factored resistance],  $\phi_b M_{Nv}$ , by using the LRFD approach, slightly different resistance factors are used for the sections with stiffened or partially stiffened compression flanges and the sections with unstiffened compression flanges.

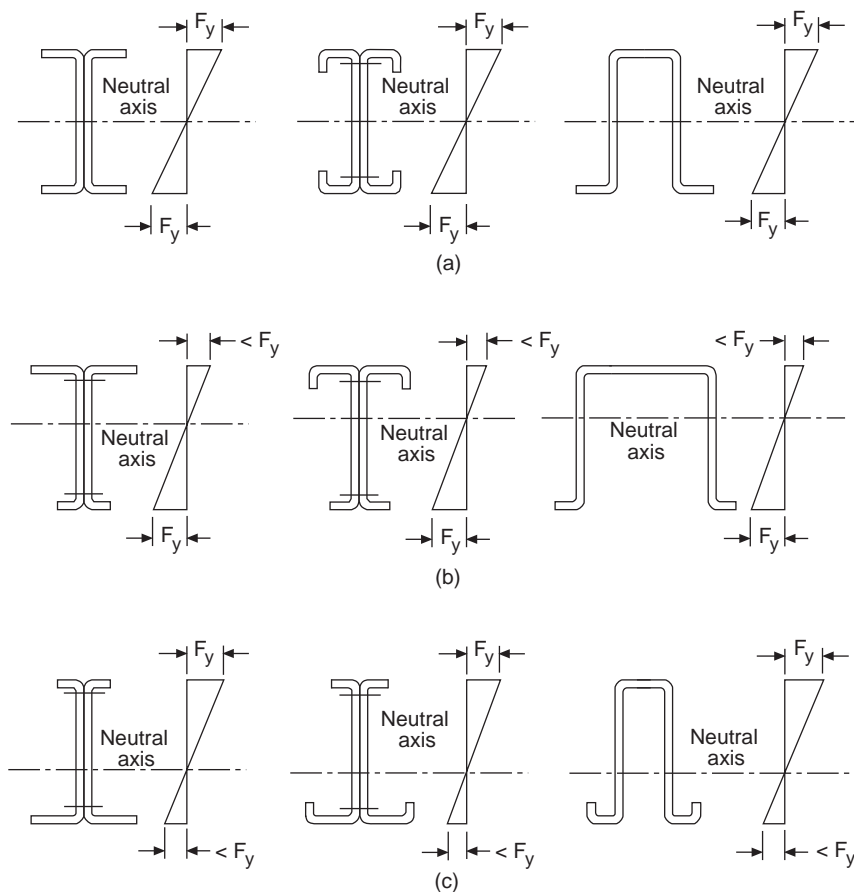

**Figure C-C3.1.1-1 Stress Distribution for Yield Moment**  
**(a) Balanced Sections, (b) Neutral Axis Close to Compression Flange,**  
**(c) Neutral Axis Close to Tension Flange**

The nominal flexural strength [moment resistance],  $M_{Nv}$ , shall be calculated either on the basis of initiation of yielding in the effective

section.

For sections with stiffened or partially stiffened compression flanges:

USA and Mexico		Canada
$\Omega_b(\text{ASD})$	$\phi_b(\text{LRFD})$	$\phi_b(\text{LSD})$
1.67	0.95	0.90

For sections with unstiffened compression flanges:

USA and Mexico		Canada
$\Omega_b(\text{ASD})$	$\phi_b(\text{LRFD})$	$\phi_b(\text{LSD})$
1.67	0.90	0.90

Effective yield moment based on section strength [resistance],  $M_n$ , shall be determined as follows:

$$M_n = S_e F_y \quad (\text{Eq. C3.1.1-1})$$

where

$F_y$  = Design yield point as determined in Section A7.1

$S_e$  = Elastic section modulus of effective section calculated relative to extreme compression or tension fiber at  $F_y$

When applicable, effective design widths shall be used in calculating section properties.  $M_n$  shall be calculated considering equilibrium of stresses, assuming an ideally elastic-plastic stress-strain curve which is the same in tension as in compression, assuming small deformation and assuming that plane sections remain plane during bending.

## C3.2 Shear

### C3.2.1 Shear Strength [Resistance] of Webs without Holes

The shear strength [resistance] of beam webs is governed by either yielding or buckling, depending on the  $h/t$  ratio and the mechanical properties of steel.

The *Specification* provisions are applicable for the design of webs of beams and decks either with or without transverse web stiffeners.

The nominal strength [resistance] equations of Section C3.2.1 of the *Specification* are similar to the nominal shear strength [resistance] equations given in the *AISI LRFD Specification* (AISI, 1991).

For webs with holes, Section C3.2.2 of AISI S100 provides design guidance.

The nominal shear strength [resistance],  $V_n$ , shall be calculated as follows:

$$V_n = A_w F_v \quad (\text{Eq. C3.2.1-1})$$

(a) For  $h/t \leq \sqrt{E k_v / F_y}$

$$F_v = 0.60 F_y \quad (\text{Eq. C3.2.1-2})$$

(b) For  $\sqrt{E k_v / F_y} < h/t \leq 1.51 \sqrt{E k_v / F_y}$

$$F_v = \frac{0.60 \sqrt{E k_v F_y}}{(h/t)} \quad (\text{Eq. C3.2.1-3})$$

(c) For  $h/t > 1.51 \sqrt{E k_v / F_y}$

$$F_v = \frac{\pi^2 E k_v}{12(1 - \mu^2)(h/t)^2} = 0.904 E k_v / (h/t)^2 \quad (\text{Eq. C3.2.1-4})$$

USA and Mexico		Canada
$\Omega_v$ (ASD)	$\phi_v$ (LRFD)	$\phi_v$ (LSD)
1.60	0.95	0.80

where

$A_w$  = Area of web element =  $ht$

$E$  = Modulus of elasticity of steel

$F_v$  = Nominal shear stress

$V_n$  = Nominal shear strength [resistance]

$t$  = Web thickness

$h$  = Depth of flat portion of web measured along plane of web

$\mu$  = Poisson's ratio = 0.3

$k_v$  = Shear buckling coefficient determined as follows:

1. For unreinforced webs,  $k_v = 5.34$
2. For webs with transverse stiffeners satisfying the requirements of Section C3.6

when  $a/h \leq 1.0$

$$k_v = 4.00 + \frac{5.34}{(a/h)^2} \quad (\text{Eq. C3.2.1-5})$$

when  $a/h > 1.0$

$$k_v = 5.34 + \frac{4.00}{(a/h)^2} \quad (\text{Eq. C3.2.1-6})$$

where

$a$  = Shear panel length of unreinforced web element  
 = Clear distance between transverse stiffeners of reinforced web elements.

For a web consisting of two or more sheets, each sheet shall be considered as a separate element carrying its share of the shear force.

### C3.3 Combined Bending and Shear

For cantilever beams and continuous beams, high bending stresses often combine with high shear stresses at the supports. Such beam webs must be

safeguarded against buckling due to the combination of bending and shear stresses.

### C3.3.1 ASD Method

For beams subjected to combined bending and shear, the required allowable flexural strength,  $M$ , and required allowable shear strength,  $V$ , shall not exceed  $M_n/\Omega_b$  and  $V_n/\Omega_v$ , respectively.

For beams with unreinforced webs, the required allowable flexural strength,  $M$ , and required allowable shear strength,  $V$ , shall also satisfy the following interaction equation:

$$\sqrt{\left(\frac{\Omega_b M}{M_{nxo}}\right)^2 + \left(\frac{\Omega_v V}{V_n}\right)^2} \leq 1.0 \quad (\text{Eq. C3.3.1-1})$$

For beams with transverse web stiffeners, when  $\Omega_b M/M_{nxo} > 0.5$  and  $\Omega_v V/V_n > 0.7$ ,  $M$  and  $V$  shall also satisfy the following interaction equation:

$$0.6\left(\frac{\Omega_b M}{M_{nxo}}\right) + \left(\frac{\Omega_v V}{V_n}\right) \leq 1.3 \quad (\text{Eq. C3.3.1-2})$$

where:

$\Omega_b$  = Factor of safety for bending (See Section C3.1.1)

$\Omega_v$  = Factor of safety for shear (See Section C3.2)

$M_n$  = Nominal flexural strength when bending alone is considered

$M_{nxo}$  = Nominal flexural strength about centroidal x-axis determined in accordance with Section C3.1.1

$V_n$  = Nominal shear strength when shear alone is considered

### C3.3.2 LRFD Method

For beams subjected to combined bending and shear, the required flexural strength [factored moment],  $\bar{M}$ , and the required shear strength [factored shear],  $\bar{V}$ , shall not exceed  $\phi_b M_n$  and  $\phi_v V_n$ , respectively.

For beams with unreinforced webs, the required flexural strength [factored moment],  $\bar{M}$ , and the required shear strength [factored shear],  $\bar{V}$ , shall also satisfy the following interaction equation:

$$\left(\frac{\bar{M}}{\phi_b M_{nxo}}\right)^2 + \left(\frac{\bar{V}}{\phi_v V_n}\right)^2 \leq 1.0 \quad (\text{Eq. C3.3.2-1})$$

For beams with transverse web stiffeners, when  $\bar{M}/(\phi_b M_{nxo}) > 0.5$  and  $\bar{V}/(\phi_v V_n) > 0.7$ ,  $\bar{M}$  and  $\bar{V}$  shall also satisfy the following interaction equation:

$$0.6\left(\frac{\bar{M}}{\phi_b M_{nxo}}\right) + \left(\frac{\bar{V}}{\phi_v V_n}\right) \leq 1.3 \quad (\text{Eq. C3.3.2-2})$$

where:

$\phi_b$  = Resistance factor for bending (See Section C3.1.1)

$\phi_v$  = Resistance factor for shear (See Section C3.2)

$M_n$  = Nominal flexural strength [moment resistance] when bending alone is considered

$M_{nxo}$  = Nominal flexural strength [moment resistance] about centroidal x-axis determined in accordance with Section C3.1.1

$\bar{M}$  = Required flexural strength [factored moment]

$\bar{M} = M_u$  (LRFD)

$\bar{M} = M_f$  (LSD)

$V_n$  = Nominal shear strength [resistance] when shear alone is considered

$\bar{V}$  = Required shear strength [factored shear]

$\bar{V} = V_u$  (LRFD)

$\bar{V} = V_f$  (LSD)

### C3.4 Web Crippling

#### C3.4.1 Web Crippling Strength [Resistance] of Webs without Holes

Since cold-formed steel flexural members generally have large web slenderness ratios, the webs of such members may cripple due to the high local intensity of the load or reaction. Figure C-C3.4.1-1 shows typical web crippling failure modes of unreinforced single hat sections (Figure C-C3.4.1-1(a)) and of I-sections (Figure C-C3.4.1-1(b)) unfastened to the support.

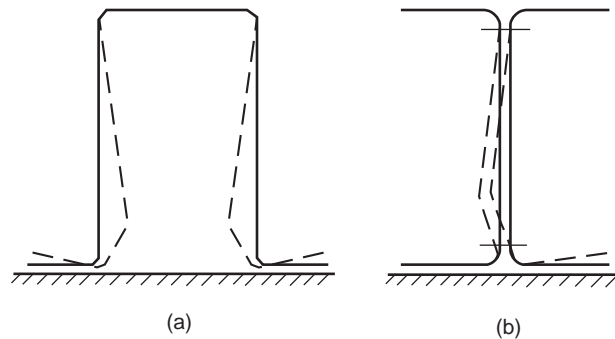
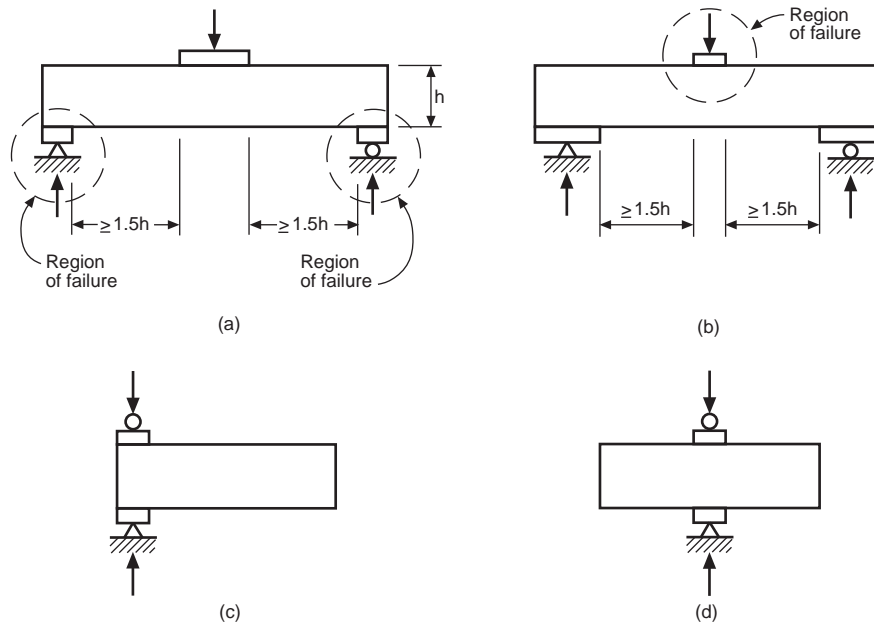

Figure C-C3.4.1-1 Web Crippling of Cold-Formed Steel Sections

The theoretical analysis of web crippling for cold-formed steel flexural members is rather complicated because it involves the following factors: (1) nonuniform stress distribution under the applied load and adjacent portions of the web, (2) elastic and inelastic stability of the web element, (3) local yielding in the immediate region of load application, (4) bending produced by eccentric load (or reaction) when it is applied on the bearing flange at a distance beyond the curved transition of the web, (5) initial out-of-plane imperfection of plate elements, (6) various edge restraints provided by beam flanges and interaction

between flange and web elements, and (7) inclined webs for decks and panels.



**Figure C-C3.4.1-2 Loading Conditions for Web Crippling Tests**  
**(a) EOF Loading, (b) IOF Loading, (c) ETF Loading, (d) ITF Loading**

For these reasons, the present AISI design provision for web crippling is based on the extensive experimental investigations. In these experimental investigations, the web crippling tests were carried out under the following four loading conditions for beams having single unreinforced webs and I-beams, single hat sections and multi-web deck sections:

1. End one-flange (EOF) loading
2. Interior one-flange (IOF) loading
3. End two-flange (ETF) loading
4. Interior two-flange (ITF) loading

All loading conditions are illustrated in Figure C-C3.4.1-2. In Figures (a) and (b), the distances between bearing plates were kept to no less than 1.5 times the web depth in order to avoid the two-flange loading action. Application of the various load cases is shown in Figure C-C3.4.1-3 and the assumed reaction or load distributions are illustrated in Figure C-C3.4.1-4.

For webs with holes, Section C3.4.2 of AISI S100 provides design guidance.

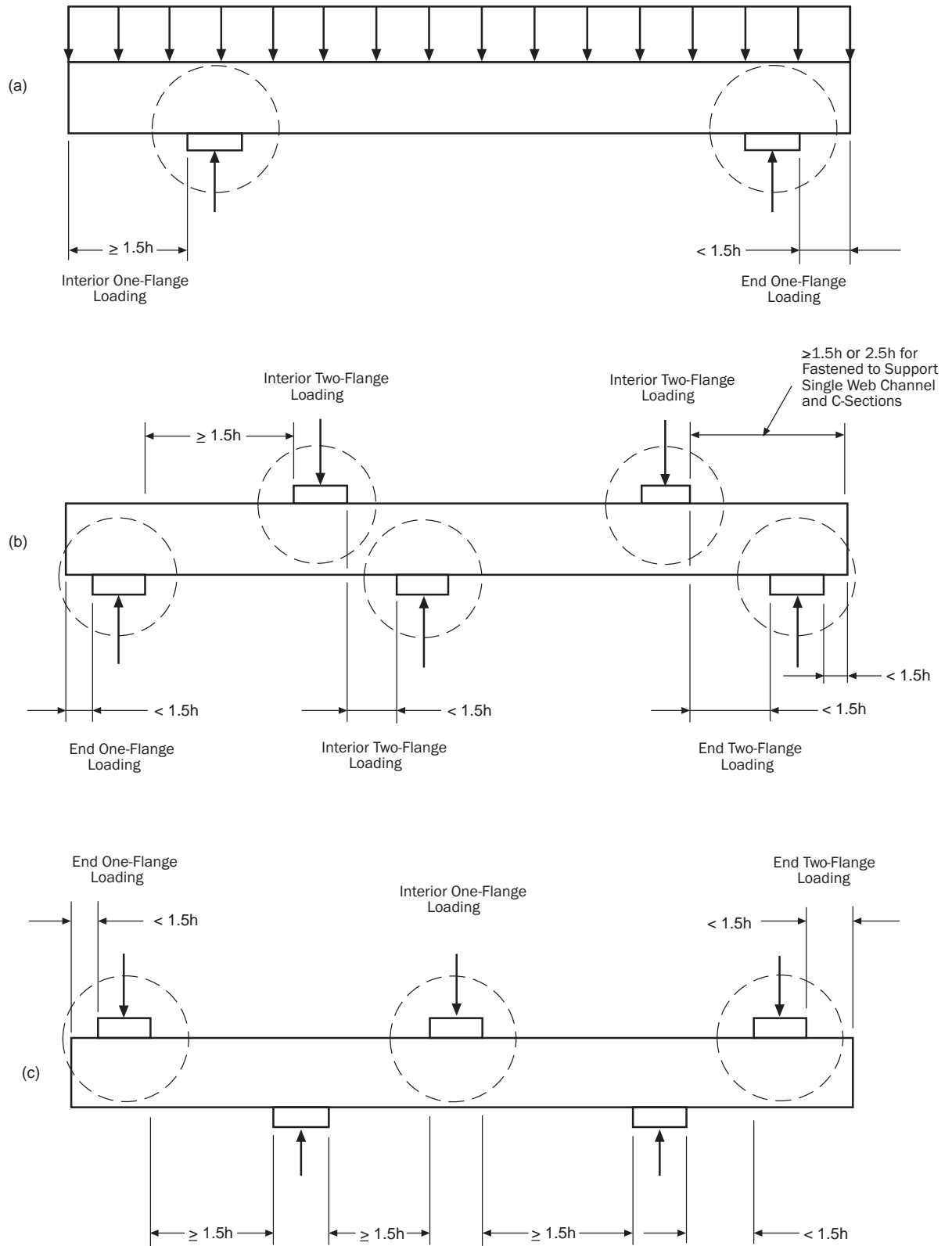

Figure C-C3.4.1-3 Application of Loading Cases

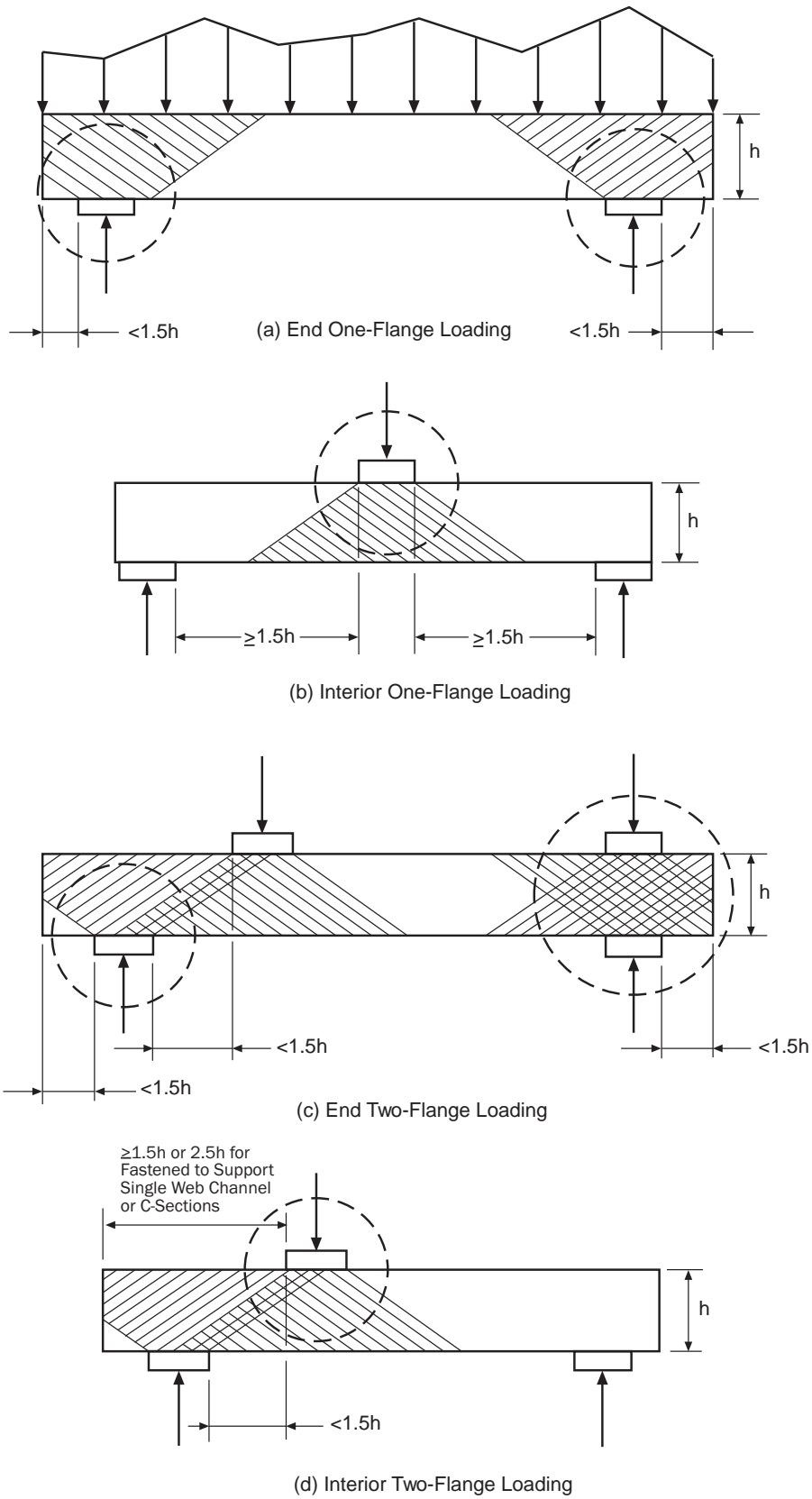

Figure C-C3.4.1-4 Assumed Distribution of Reaction or Load

The nominal web crippling strength [resistance],  $P_n$ , shall be determined as follows:

$$P_n = Ct^2F_y \sin \theta \left( 1 - C_R \sqrt{\frac{R}{t}} \right) \left( 1 + C_N \sqrt{\frac{N}{t}} \right) \left( 1 - C_h \sqrt{\frac{h}{t}} \right) \quad (\text{Eq. C3.4.1-1})$$

where:

$P_n$  = Nominal web crippling strength [resistance]

$C$  = Coefficient from Table C3.4.1-2

$C_h$  = Web slenderness coefficient from Table C3.4.1-2

$C_N$  = Bearing length coefficient from Table C3.4.1-2

$C_R$  = Inside bend radius coefficient from Table C3.4.1-2

$F_y$  = Design yield point as determined in Section A7.1

$h$  = Flat dimension of web measured in plane of web

$N$  = Bearing length [3/4 in. (19 mm) minimum]

$R$  = Inside bend radius

$t$  = Web thickness

$\theta$  = Angle between plane of web and plane of bearing surface,  
 $45^\circ \leq \theta \leq 90^\circ$

Webs of members in bending for which  $h/t$  is greater than 200 shall be provided with adequate means of transmitting concentrated loads or reactions directly into the web(s).

$P_n$  represents the nominal strength [resistance] for load or reaction for one solid web connecting top and bottom flanges. For webs consisting of two or more such sheets,  $P_n$  shall be calculated for each individual sheet and the results added to obtain the nominal strength for the full section.

One-flange loading or reaction shall be defined as the condition where the clear distance between the bearing edges of adjacent opposite concentrated loads or reactions is greater than  $1.5h$ .

Two-flange loading or reaction shall be defined as the condition where the clear distance between the bearing edges of adjacent opposite concentrated loads or reactions is equal to or less than  $1.5h$ .

End loading or reaction shall be defined as the condition where the distance from the edge of the bearing to the end of the member is equal to or less than  $1.5h$ .

Interior loading or reaction shall be defined as the condition where the distance from the edge of the bearing to the end of the member is greater than  $1.5h$ , except as otherwise noted herein.

**TABLE C3.4.1-2**  
**Safety Factors, Resistance Factors, and Coefficients for Single Web Channel and C-Sections**

Support and Flange Conditions		Load Cases		C	C <sub>R</sub>	C <sub>N</sub>	C <sub>h</sub>	USA and Mexico		Canada LSD φ <sub>w</sub>	Limits
								ASD Ω <sub>w</sub>	LRFD φ <sub>w</sub>		
Fastened to Support	Stiffened or Partially Stiffened Flanges	One-Flange Loading or Reaction	End	4	0.14	0.35	0.02	1.75	0.85	0.75	R/t ≤ 9
			Interior	13	0.23	0.14	0.01	1.65	0.90	0.80	R/t ≤ 5
		Two-Flange Loading or Reaction	End	7.5	0.08	0.12	0.048	1.75	0.85	0.75	R/t ≤ 12
			Interior	20	0.10	0.08	0.031	1.75	0.85	0.75	R/t ≤ 12
Unfastened	Stiffened or Partially Stiffened Flanges	One-Flange Loading or Reaction	End	4	0.14	0.35	0.02	1.85	0.80	0.70	R/t ≤ 5
			Interior	13	0.23	0.14	0.01	1.65	0.90	0.80	
		Two-Flange Loading or Reaction	End	13	0.32	0.05	0.04	1.65	0.90	0.80	R/t ≤ 3
			Interior	24	0.52	0.15	0.001	1.90	0.80	0.65	
	Unstiffened Flanges	One-Flange Loading or Reaction	End	4	0.40	0.60	0.03	1.80	0.85	0.70	R/t ≤ 2
			Interior	13	0.32	0.10	0.01	1.80	0.85	0.70	R/t ≤ 1
		Two-Flange Loading or Reaction	End	2	0.11	0.37	0.01	2.00	0.75	0.65	R/t ≤ 1
			Interior	13	0.47	0.25	0.04	1.90	0.80	0.65	

Note:

- (1) The above coefficients apply when  $h/t \leq 200$ ,  $N/t \leq 210$ ,  $N/h \leq 2.0$  and  $\theta = 90^\circ$ .
- (2) For interior two-flange loading or reaction of members having flanges fastened to the support, the distance from the edge of bearing to the end of the member shall be extended at least  $2.5h$ . For unfastened cases, the distance from the edge of bearing to the end of the member shall be extended at least  $1.5h$ .

### C3.5 Combined Bending and Web Crippling

#### C3.5.1 ASD Method

Unreinforced flat webs of shapes subjected to a combination of bending and concentrated load or reaction shall be designed to meet the following requirements:

For shapes having single unreinforced webs:

$$0.91 \left( \frac{P}{P_n} \right) + \left( \frac{M}{M_{nxo}} \right) \leq 1.33/\Omega \quad (\text{Eq. C3.5.1-1})$$

In the above equations:

Ω = Factor of safety for combined bending and web crippling = 1.70

P = Required allowable strength for concentrated load or reaction in the presence of bending moment

- $P_n$  =Nominal strength for concentrated load or reaction in absence of bending moment determined in accordance with Section C3.4
- $M$  =Required allowable flexural strength at, or immediately adjacent to, the point of application of the concentrated load or reaction,  $P$
- $M_{nxo}$ =Nominal flexural strength about the centroidal x-axis determined in accordance with Section C3.1.1
- $w$  =Flat width of beam flange which contacts bearing plate
- $t$  =Thickness of web or flange
- $\lambda$  =Slenderness factor given by Section B2.1

### C3.5.2 LRFD Method

Unreinforced flat webs of shapes subjected to a combination of bending and concentrated load or reaction shall be designed to meet the following requirements:

- (a) For shapes having single unreinforced webs:

$$0.91 \left( \frac{P_u}{P_n} \right) + \left( \frac{M_u}{M_{nxo}} \right) \leq 1.33\phi \quad (\text{Eq. C3.5.2-1})$$

In the above equations:

- $\phi$  =Resistance factor for combined bending and web crippling = 0.90
- $\bar{P}$  =Required strength for concentrated load or reaction [factored concentrated load or reaction] in presence of bending moment
- $\bar{P} = P_u$
- $P_n$  =Nominal strength [resistance] for concentrated load or reaction in absence of bending moment determined in accordance with Section C3.4
- $\bar{M}$  =Required flexural strength [factored moment] at, or immediately adjacent to, the point of application of the concentrated load or reaction  $\bar{P}$
- $\bar{M} = M_u$
- $M_{nxo}$ = Nominal flexural strength [moment resistance] about centroidal x-axis determined in accordance with Section C3.1.1

## C4 Centrally Loaded Compression Members

Axially loaded compression members should be designed for the following limit states depending on the configuration of the cross-section, thickness of material, unbraced length, and end restraint: (1) yielding, (2) overall column buckling (flexural buckling, torsional buckling, or torsional-flexural buckling), and (3) local buckling of individual elements. For the design tables and example problems on columns, see Parts I and III of the *AISI Cold-Formed Steel Design Manual* (AISI, 2002).

### A. Yielding

It is well known that a very short, compact column under an axial load may fail by yielding. The yield load is determined by Equation C-C4-1:

$$P_y = A_g F_y \quad (\text{C-C4-1})$$

where  $A_g$  is the gross area of the column and  $F_y$  is the yield point of steel.

## B. Flexural Buckling of Columns

### (a) Elastic Buckling Stress

A slender, axially loaded column may fail by overall flexural buckling if the cross-section of the column is a doubly-symmetric shape, closed shape (square or rectangular tube), cylindrical shape, or point-symmetric shape. For singly-symmetric shapes, flexural buckling is one of the possible failure modes. Wall studs connected with sheathing material can also fail by flexural buckling.

The elastic critical buckling load for a long column can be determined by the following Euler equation:

$$(P_{cr})_e = \frac{\pi^2 EI}{(KL)^2} \quad (\text{C-C4-2})$$

where  $(P_{cr})_e$  is the column buckling load in the elastic range,  $E$  is the modulus of elasticity,  $I$  is the moment of inertia,  $K$  is the effective length factor, and  $L$  is the unbraced length. Accordingly, the elastic column buckling stress is

$$(F_{cr})_e = \frac{(P_{cr})_e}{A_g} = \frac{\pi^2 E}{(KL/r)^2} \quad (\text{C-C4-3})$$

in which  $r$  is the radius of gyration of the full cross section, and  $KL/r$  is the effective slenderness ratio.

### (b) Inelastic Buckling Stress

When the elastic column buckling stress computed by Equation C-C4-3 exceeds the proportional limit,  $F_{pr}$ , the column will buckle in the inelastic range. Prior to 1996, the following equation was used in the *AISI Specification* for computing the inelastic column buckling stress:

$$(F_{cr})_I = F_y \left( 1 - \frac{F_y}{4(F_{cr})_e} \right) \quad (\text{C-C4-4})$$

It should be noted that because the above equation is based on the assumption that  $F_{pr} = F_y/2$ , it is applicable only for  $(F_{cr})_e \geq F_y/2$ .

By using  $\lambda_c$  as the column slenderness parameter instead of slenderness ratio,  $KL/r$ , Equation C-C4-4 can be rewritten as follows:

$$(F_{cr})_I = \left( 1 - \frac{\lambda_c^2}{4} \right) F_y \quad (\text{C-C4-5})$$

where

$$\lambda_c = \sqrt{\frac{F_y}{(F_{cr})_e}} = \frac{KL}{r\pi} \sqrt{\frac{F_y}{E}} \quad (\text{C-C4-6})$$

Accordingly, Equation C-C4-5 is applicable only for  $\lambda_c \leq \sqrt{2}$ .

(c) *Nominal Axial Strength [Compressive Resistance] for Locally Stable Columns*

If the individual components of compression members have small  $w/t$  ratios, local buckling will not occur before the compressive stress reaches the column buckling stress or the yield point of steel. Therefore, the nominal axial strength [compressive resistance] can be determined by the following equation:

$$P_n = A_g F_{cr} \quad (\text{C-C4-7})$$

where

$P_n$  = nominal axial strength

$A_g$  = gross area of the column

$F_{cr}$  = column buckling stress

(d) *Nominal Axial Strength [Compressive Resistance] for Locally Unstable Columns*

For cold-formed steel compression members with large  $w/t$  ratios, local buckling of individual component plates may occur before the applied load reaches the nominal axial strength [compressive resistance] determined by Equation C-C4-7. The interaction effect of the local and overall column buckling may result in a reduction of the overall column strength [resistance]. From 1946 through 1986, the effect of local buckling on column strength was considered in the *AISI Specification* by using a form factor  $Q$  in the determination of allowable stress for the design of axially loaded compression members (Winter, 1970; Yu, 2000). Even though the  $Q$ -factor method was used successfully for the design of cold-formed steel compression members, research work conducted at Cornell University and other institutions have shown that this method is capable of improvement. On the basis of the test results and analytical studies of DeWolf, Pekoz, Winter, and Mulligan (DeWolf, Pekoz and Winter, 1974; Mulligan and Pekoz, 1984) and Pekoz's development of a unified approach for the design of cold-formed steel members (Pekoz, 1986b), the  $Q$ -factor method was eliminated in the 1986 edition of the *AISI Specification*. In order to reflect the effect of local buckling on the reduction of column strength, the nominal axial strength [compressive resistance] is determined by the critical column buckling stress and the *effective area*,  $A_e$ , instead of the full sectional area. When  $A_e$  cannot be calculated, such as when the compression member has dimensions or geometry beyond the range of applicability of the *AISI Specification*, the effective area  $A_e$  can be determined experimentally by stub column tests using the procedure given in Part VIII of the *AISI Design Manual* (AISI, 2002). For a more in-depth discussion of the background for these provisions, see Pekoz (1986b). Therefore, the nominal axial strength [compressive resistance] of cold-formed steel compression members can be determined by the following equation:

$$P_n = A_e F_{cr}$$

(C-C4-8)

where  $F_{cr}$  is either elastic buckling stress or inelastic buckling stress whichever is applicable, and  $A_e$  is the effective area at  $F_{cr}$ .

This section applies to members in which the resultant of all loads acting on the member is an axial load passing through the centroid of the effective section calculated at the stress,  $F_n$ , defined in this section.

The nominal axial strength [compressive resistance],  $P_n$ , shall be calculated as follows:

$$P_n = A_e F_n \quad (Eq. C4.1-1)$$

USA and Mexico		Canada
$\Omega_c$ (ASD)	$\phi_c$ (LRFD)	$\phi_c$ (LSD)
1.80	0.85	0.80

where

$A_e$  = Effective area calculated at stress  $F_n$ .

$F_n$  is determined as follows:

$$\text{For } \lambda_c \leq 1.5 \quad F_n = \left( 0.658 \lambda_c^2 \right) F_y \quad (Eq. C4.1-2)$$

$$\text{For } \lambda_c > 1.5 \quad F_n = \left[ \frac{0.877}{\lambda_c^2} \right] F_y \quad (Eq. C4.1-3)$$

where

$$\lambda_c = \sqrt{\frac{F_y}{F_e}} \quad (Eq. C4.1-4)$$

$F_e$  = The least of the elastic flexural, torsional and torsional-flexural buckling stress determined according to Sections C4.1 through C4.4.

#### C4.1.1 Sections Not Subject to Torsional or Torsional-Flexural Buckling

For doubly-symmetric sections, closed cross sections and any other sections which can be shown not to be subject to torsional or torsional-flexural buckling, the elastic flexural buckling stress,  $F_e$ , shall be determined as follows:

$$F_e = \frac{\pi^2 E}{(KL/r)^2} \quad (Eq. C4.1.1.1-1)$$

where

$E$  = Modulus of elasticity

$K$  = Effective length factor

$L$  = Laterally unbraced length of member

$r$  = Radius of gyration of full unreduced cross section about axis of

buckling

In frames where lateral stability is provided by diagonal bracing, shear walls, attachment to an adjacent structure having adequate lateral stability, or floor slabs or roof decks secured horizontally by walls or bracing systems parallel to the plane of the frame, and in trusses, the effective length factor,  $K$ , for compression members which do not depend upon their own bending stiffness for lateral stability of the frame or truss, shall be taken as unity, unless analysis shows that a smaller value shall be permitted to be used. In a frame which depends upon its own bending stiffness for lateral stability, the effective length,  $KL$ , of the compression members shall be determined by a rational method and shall not be less than the actual unbraced length.

#### **C4.1.2 Doubly- or Singly-Symmetric Sections Subject to Torsional or Flexural-Torsional Buckling**

As discussed previously in Section C4, torsional buckling is one of the possible buckling modes for doubly- and point-symmetric sections. For singly-symmetric sections, torsional-flexural buckling is one of the possible buckling modes. The other possible buckling mode is flexural buckling by bending about the  $y$ -axis (i.e., assuming  $x$ -axis is the axis of symmetry).

For torsional buckling, the elastic buckling stress can be calculated by using Equation C-C4-13. For torsional-flexural buckling, Equation C-C4-15 can be used to compute the elastic buckling stress. The following simplified equation for elastic torsional-flexural buckling stress is an alternative permitted by the *AISI Specification*:

$$F_e = \frac{\sigma_t \sigma_{ex}}{\sigma_t + \sigma_{ex}} \quad (\text{C-C4-16})$$

The above equation is based on the following interaction relationship given by Pekoz and Winter (1969a):

$$\frac{1}{P_n} = \frac{1}{P_x} + \frac{1}{P_z} \quad (\text{C-C4-17})$$

or

$$\frac{1}{F_e} = \frac{1}{\sigma_{ex}} + \frac{1}{\sigma_t} \quad (\text{C-C4-18})$$

Research at the University of Sydney (Popovic, Hancock, and Rasmussen, 1999) has shown that singly-symmetric unstiffened cold-formed steel angles, which have a fully effective cross-section under yield point, do not fail in a torsional-flexural mode and can be designed based on flexural buckling alone as specified in *Specification* Section C4.1. There is also no need to include a load eccentricity for these sections when using *Specification* Section C5.2.1 or Section C5.2.2 as explained in Item E of Section C4.

For singly-symmetric sections subject to flexural-torsional buckling,  $F_e$  shall be taken as the smaller of  $F_e$  calculated according to Section C4.1 and  $F_e$  calculated as follows:

$$F_e = \frac{1}{2\beta} \left[ (\sigma_{ex} + \sigma_t) - \sqrt{(\sigma_{ex} + \sigma_t)^2 - 4\beta\sigma_{ex}\sigma_t} \right] \quad (\text{Eq. C4.2-1})$$

Alternatively, a conservative estimate of  $F_e$  can be obtained using the following equation:

$$F_e = \frac{\sigma_t\sigma_{ex}}{\sigma_t + \sigma_{ex}} \quad (\text{Eq. C4.2-2})$$

where:

$$\beta = 1 - (x_0/r_0)^2$$

$$\sigma_{ex} = \frac{\pi^2 E}{(K_x L_x / r_x)^2}$$

$$\sigma_{ey} = \frac{\pi^2 E}{(K_y L_y / r_y)^2}$$

$$\sigma_t = \frac{1}{Ar_0^2} \left[ GJ + \frac{\pi^2 EC_w}{(K_t L_t)^2} \right]$$

For singly-symmetric sections, the x-axis is assumed to be the axis of symmetry.