

B. Elements**B1 Dimensional Limits and Considerations**

Individual structural elements of cold-formed steel are considerably thin and they also present large width-to-thickness ratios. So they are susceptible to buckle elastically, i.e, to fail under geometrical instabilities at stress level lower than the yield point, when subjected to compression in flexural bending, pure axial compression, shear or bearing. That implies the design of these types of elements should provide sufficient safety against the failure by local instability. In order to do so, section B of the specification provides design requirements for width-to-thickness ratios and equations for effective widths of compression elements (with and without stiffeners) with edge stiffeners or intermediate stiffeners.

Holes in the members are common for running utilities throughout a building. The holes can result in a strength reduction of an individual element and a strength reduction of the member itself, although not presented in the design manual. Section B2.2 guides the way to find the effective width of a stiffened compression element with a circular hole; Section B2.4 guides the way to find the effective width of a stiffened element with a circular hole under a stress gradient.

B1.1 Flange Flat-Width-to-Thickness Considerations*(a) Maximum Flat-Width-to-Thickness Ratios*

Maximum allowable overall flat-width-to-thickness ratios, w/t , disregarding intermediate stiffeners and taking as t , the actual thickness of the element, shall be as follows:

- (1) Stiffened compression element having *one* longitudinal edge connected to a web or flange element, the other stiffened by:
 - Simple lip, $w/t \leq 60$
- (2) Stiffened compression element with both longitudinal edges connected to other stiffened elements, $w/t \leq 500$
- (3) Unstiffened compression element, $w/t \leq 60$

B1.2 Maximum Web Depth-to-Thickness Ratios

The ratio, h/t , of the webs of flexural members shall not exceed the following limitations:

- (a) For unreinforced webs: $(h/t)_{\max} = 200$
- (b) For webs which are provided with transverse stiffeners satisfying the requirements of Section C3.7.1:
 - (1) Where using bearing stiffeners only, $(h/t)_{\max} = 260$

- (2) Where using bearing stiffeners and intermediate stiffeners,
 $(h/t)_{\max} = 300$

In the above,

h = Depth of flat portion of web measured along plane of web

t = Web thickness

Where a web consists of two or more sheets, the h/t ratio shall be computed for the individual sheets.

B2.1 Uniformly Compressed Stiffened Elements

Maximum flat width-to-thickness ratios are limited by Section B1.1a in the Specification. Each individual element of a member is considered. The width is taken as the distance between but not including the stiffeners (e.g. Figure B2.1-1). The thickness is the uncoated thickness of the steel.

Maximum web depth-to-thickness ratios use similar concepts as the AISC Specification. Here, the height of the web is taken as the depth, not including stiffeners. The limitations on the h/t ratio are set in the AISI Specification.

If the w/t ratio is small, the stress in the compression flange can reach the yield point of steel and the strength of the compression element is governed by yielding. For the compression flange with large w/t ratios, local buckling (Figure C-B-1) will occur. To reflect the reduced strength of a member resulting from local buckling, an effective width is used in place of the actual width. The effective width is illustrated by Figure B2.1-1.

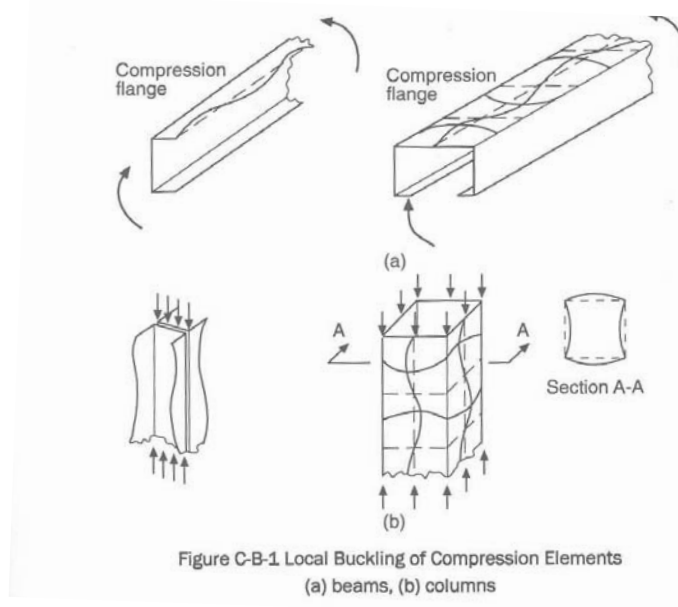

(a) *Strength Determination*

The effective width, b , shall be determined from the following equations:

$$b = w \quad \text{when } \lambda \leq 0.673 \quad (\text{Eq. B2.1-1})$$

$$b = \rho w \quad \text{when } \lambda > 0.673 \quad (\text{Eq. B2.1-2})$$

where

w = Flat width as shown in Figure B2.1-1

$$\rho = (1 - 0.22/\lambda)/\lambda \quad (\text{Eq. B2.1-3})$$

λ = Slenderness factor

$$\lambda = \sqrt{\frac{f}{F_{cr}}} \quad (\text{Eq. B2.1-4})$$

f = Stress in compression element computed as follows:

For flexural members:

(1) If Procedure I of Section C3.1.1 is used:

When the initial yielding is in compression in the element considered, $f = F_y$.

When the initial yielding is in tension, the compressive stress, f , in the element considered shall be determined on the basis of the effective section at M_y (moment causing initial yield).

(2) If Section C3.1.2.1 is used, f is the stress F_c as described in that Section in determining S_c .

For compression members, f is taken equal to F_n as determined in Section C4.

$$F_{cr} = k \frac{\pi^2 E}{12(1 - \mu^2)} \left(\frac{t}{w} \right)^2 \quad (\text{Eq. B2.1-5})$$

where

k = Plate buckling coefficient

= 4 for stiffened elements supported by a web on each longitudinal edge.

Values for different types of elements are given in the applicable sections.

t = Thickness of uniformly compressed stiffened element

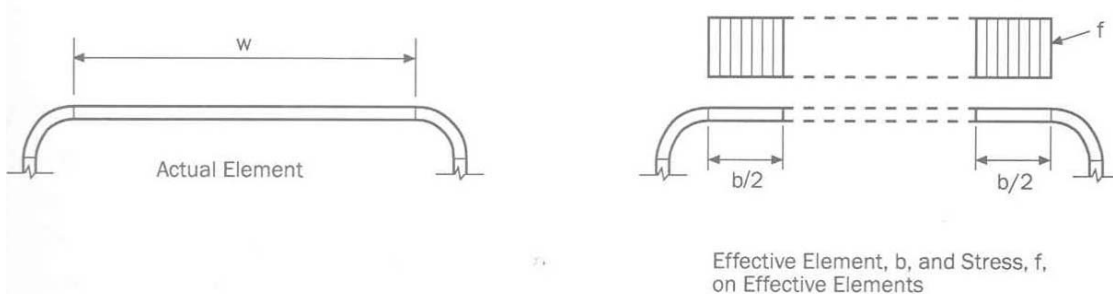

Figure B2.1-1 Stiffened Elements

μ = Poisson's ratio of steel, and

E = Modulus of elasticity

(b) *Serviceability Determination*

The effective width, b_d , used in determining serviceability shall be calculated from the following equations:

$$b_d = w \quad \text{when } \lambda \leq 0.673 \quad (\text{Eq. B2.1-6})$$

$$b_d = \rho w \quad \text{when } \lambda > 0.673 \quad (\text{Eq. B2.1-7})$$

where

w = Flat width

ρ = Reduction factor determined by Eq. B2.1-3.

$$\lambda = \sqrt{\frac{f}{F_{cr}}}$$

f_d is substituted for f , where f_d is the computed compressive stress in the element being considered.

B2.3 Webs and other Stiffened Elements under Stress Gradient

When a beam is subjected to bending moment, the compression portion of the web may buckle due to the compressive stress caused by bending.

The following notation is used in this section:

b_1 = Effective width, dimension defined in Figure B2.3-1

b_2 = Effective width, dimension defined in Figure B2.3-1

b_e = Effective width b determined in accordance with Section B2.1 with f_1 substituted for f and with k determined as given in this section

b_o = Out-to-out width of the compression flange as defined in Figure B2.3-2

f_1, f_2 = Stresses shown in Figure B2.3-1 calculated on the basis of effective section. Where f_1 and f_2 are both compression, $f_1 \geq f_2$

h_o = Out-to-out depth of web as defined in Figure B2.3-2

k = Plate buckling coefficient

ψ = $|f_2/f_1|$ (absolute value) (Eq. B2.3-1)

(a) *Strength Determination*

For webs under stress gradient (f_1 in compression and f_2 in tension as shown in Figure B2.3-1)

$$k = 4 + 2(1 + \psi)^3 + 2(1 + \psi) \quad (\text{Eq. B2.3-2})$$

For $h_o/b_o \leq 4$

$$b_1 = b_e / (3 + \psi) \quad (\text{Eq. B2.3-3})$$

$$b_2 = b_e / 2 \quad \text{when } \psi > 0.236 \quad (\text{Eq. B2.3-4})$$

$$b_2 = b_e - b_1 \quad \text{when } \psi \leq 0.236 \quad (\text{Eq. B2.3-5})$$

In addition, $b_1 + b_2$ shall not exceed the compression portion of the web calculated on the basis of effective section.

For $h_o/b_o > 4$

$$b_1 = b_e / (3 + \psi)$$

(Eq. B2.3-6)

$$b_2 = b_e / (1 + \psi) - b_1$$

(Eq. B2.3-7)

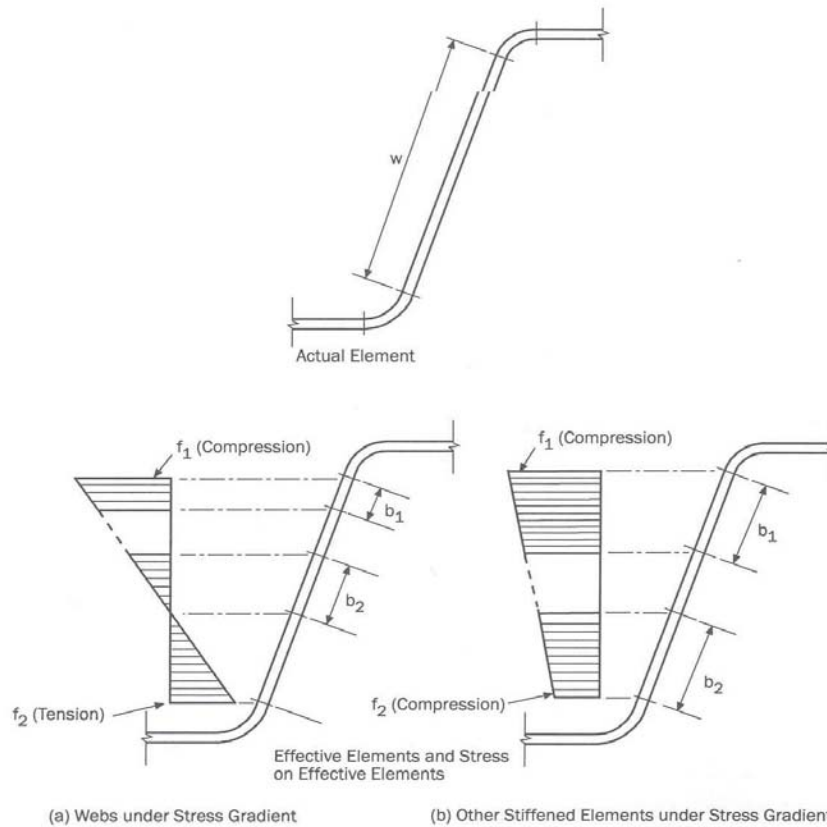

Figure B2.3-1 Webs and other Stiffened Elements under Stress Gradient

(b) Serviceability Determination

The effective widths used in determining serviceability shall be calculated in accordance with Section B2.3(a) except that f_{d1} and f_{d2} are substituted for f_1 and f_2 , where f_{d1} and f_{d2} are the computed stresses f_1 and f_2 based on the effective section at the load for which serviceability is determined.

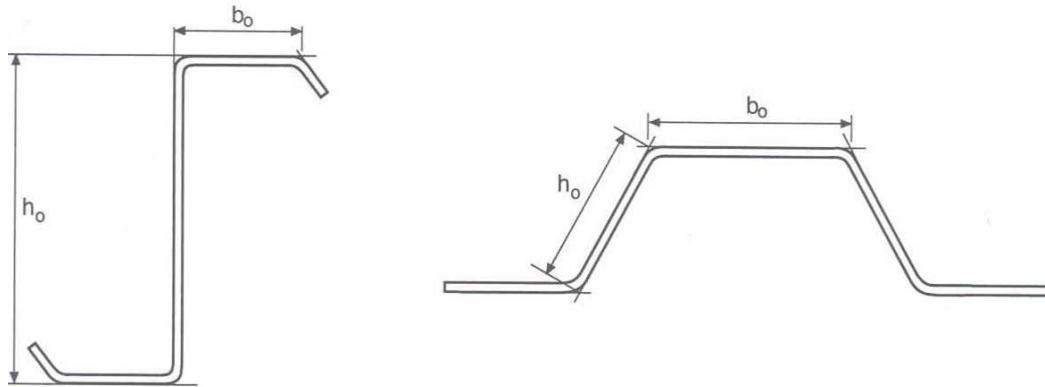

Figure B2.3-2 Out-to-Out Dimension of Webs and Stiffened Elements Under Stress Gradient

B3 Effective Widths of Unstiffened Elements

Similar to stiffened compression elements, the stress in the unstiffened compression elements can reach to the yield point of steel if the w/t ratio is small. Because the unstiffened element has one longitudinal edge supported by the web and the other edge is free, the limiting width-to-thickness ratio of unstiffened elements is much less than that for stiffened elements.

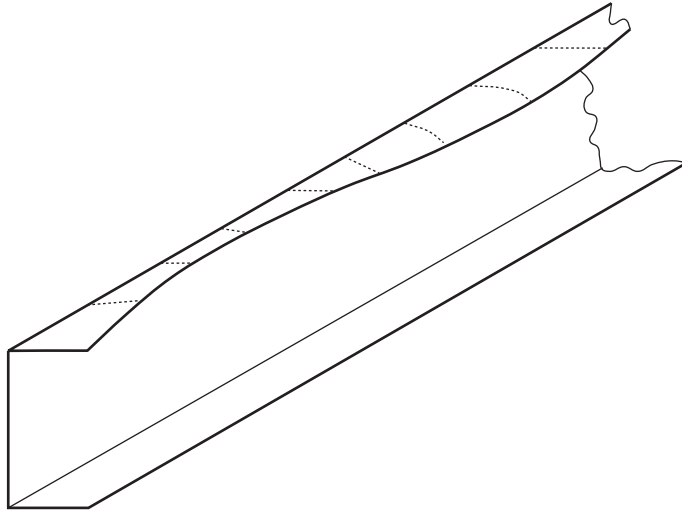

Figure C-B3-1 Local Buckling of Unstiffened Compression Flange

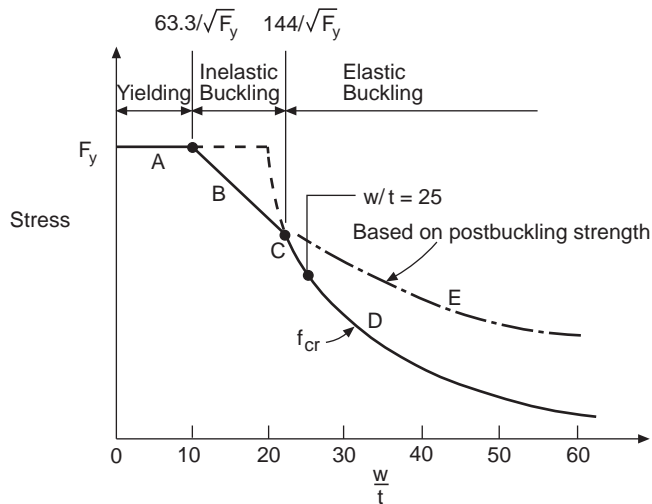

Figure C-B3-2 Maximum Stress for Unstiffened Compression Elements

B3.1 Uniformly Compressed Unstiffened Elements

(a) Strength Determination

The effective width, b , shall be determined in accordance with Section B2.1(a), except that k shall be taken as 0.43 and w as defined in Figure B3.1-1.

(b) Serviceability Determination

The effective width, b_d , used in determining serviceability shall be calculated in accordance with Procedure I of Section B2.1(b), except that f_d is substituted for f and $k = 0.43$.

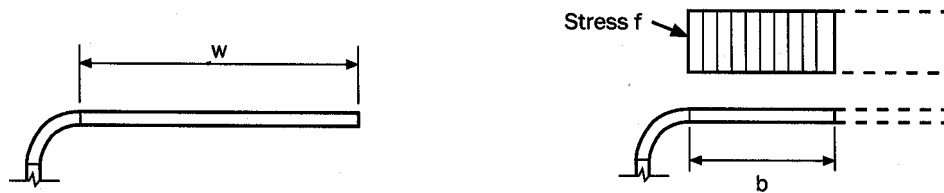

Figure B3.1-1 Unstiffened Element with Uniform Compression

B3.2 Unstiffened Elements and Edge Stiffeners under Stress Gradient

In concentrically loaded compression members and in flexural members where the unstiffened compression element is parallel to the neutral axis, the stress distribution is uniform prior to local buckling. However, when edge stiffeners of the compression element are present, the compressive stress in the edge stiffener is not uniform but varies in proportion to the distance from the neutral axis. The unstiffened element (the edge stiffener) in this case has compressive stress applied at both longitudinal edges. The unstiffened element of a section may also be subjected to stress gradients causing tension at one longitudinal edge and compression at the other longitudinal edge. This can occur in I-sections, plain channel sections and angle sections in minor axis bending.

The effective width, b , (measured from the supported edge) of unstiffened elements with stress gradient causing compression at both longitudinal edges, is calculated using the Winter equation. For unstiffened elements with stress gradients causing tension at one longitudinal edge and compression at the other longitudinal edge, modified Winter equations are specified when tension exists at either the supported or the unsupported edges. The effective width equations apply to any unstiffened element under stress gradient, and are not restricted to particular cross-sections. Figure C-B3.2-1 demonstrates how the effective width of an unstiffened element increases as the stress at the supported edge changes from compression to tension. As shown in the figure, the effective width curve is independent of the stress ratio, ψ , when both edges are in compression. In this case, the effect of stress ratio is accounted for by the plate buckling coefficient, k , which varies with stress ratio and affects the slenderness, λ . When the supported edge is in tension and the unsupported edge is in compression, both the effective width curve and the plate buckling coefficient depend on the stress ratio, as per Equations B3.2-4 and B3.2-5 of the Specification.

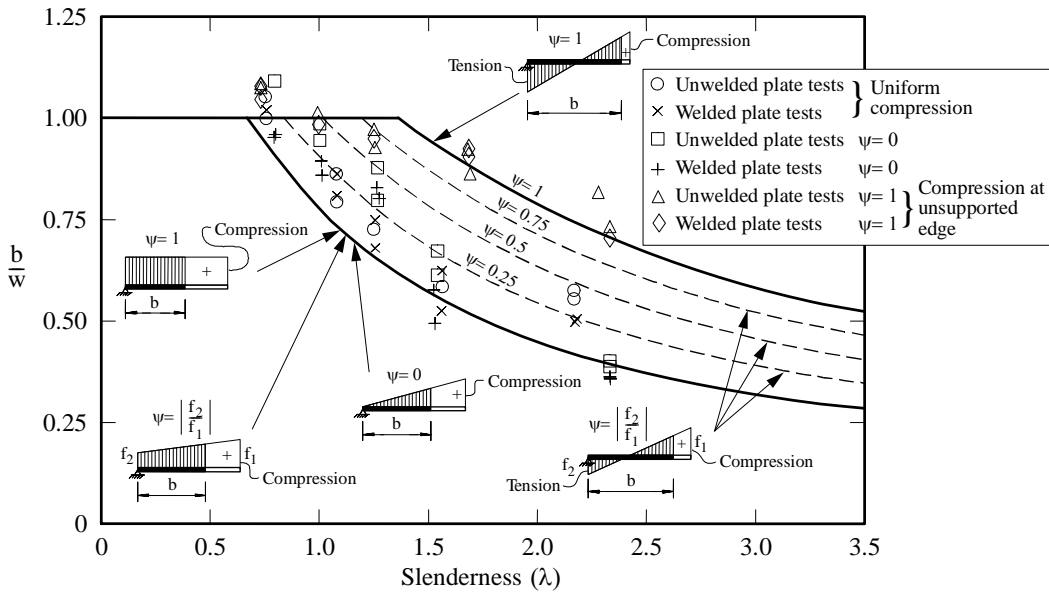

Figure C-B3.2-1 Effective Width vs. Plate Slenderness

(a) Strength Determination

The effective width, b , of an unstiffened element under stress gradient shall be determined in accordance with Section B2.1(a) with f equal to f_1 and the plate buckling coefficient, k , to be determined by this section unless otherwise noted. For the cases where f_1 is in compression and f_2 is in tension, ρ in Section B2.1(a) shall be determined by this section.

(1) When both f_1 and f_2 are in compression (Fig. B3.2-1) the plate buckling coefficient shall be calculated in accordance with either Eq. B3.2-2 or Eq. B3.2-3 as follows:

If the stress decreases toward the unsupported edge (Figure B3.2-1(a)):

$$k = \frac{0.578}{\psi + 0.34} \tag{Eq. B3.2-2}$$

If the stress increases toward the unsupported edge (Figure B3.2-1(b)):

$$k = 0.57 - 0.21\psi + 0.07\psi^2 \tag{Eq. B3.2-3}$$

(2) When f_1 is in compression and f_2 in tension (Fig. B3.2-2):

(i) If the unsupported edge is in compression (Figure B3.2-2(a)):

$$\rho = 1 \quad \text{when } \lambda \leq 0.673(1 + \psi)$$

$$\rho = (1 + \psi) \frac{\left(1 - \frac{0.22(1 + \psi)}{\lambda}\right)}{\lambda} \quad \text{when } \lambda > 0.673(1 + \psi) \tag{Eq. B3.2-4}$$

$$k = 0.57 + 0.21\psi + 0.07\psi^2 \tag{Eq. B3.2-5}$$

(ii) If the supported edge is in compression (Fig. B3.2-2(b)):

For $\psi < 1$

$$\rho = 1 \quad \text{when } \lambda \leq 0.673$$

$$\rho = (1 - \psi) \left(\frac{1 - \frac{0.22}{\lambda}}{\lambda} \right) + \psi \quad \text{when } \lambda > 0.673 \quad (\text{Eq. B3.2-6})$$

$$k = 1.70 + 5\psi + 17.1\psi^2 \quad (\text{Eq. B3.2-7})$$

For $\psi \geq 1$

$$\rho = 1$$

In calculating the effective section modulus S_e in Section C3.1.1 or S_c in Section C3.1.2.1, the extreme compression fiber in Figures B3.2-1(b) and B3.2-2(a) is taken as the edge of the effective section closer to the unsupported edge. In calculating the effective section modulus S_e in Section C3.1.1, the extreme tension fiber in Figure B3.2-2(b) is taken as the edge of the effective section closer to the unsupported edge.

(b) *Serviceability Determination*

The effective width b_d used in determining serviceability shall be calculated in accordance with Section B3.2(a) except that f_{d1} and f_{d2} are substituted for f_1 and f_2 respectively, where f_{d1} and f_{d2} are the computed stresses f_1 and f_2 as shown in Figures B3.2-1, B3.2-2 and B3.2-3, respectively, based on the gross section at the load for which serviceability is determined.

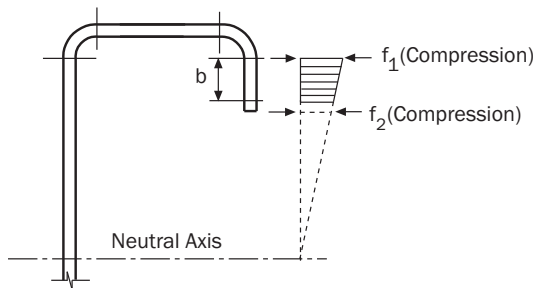

(a) Inward Facing Lip

Figure B3.2-1(a)

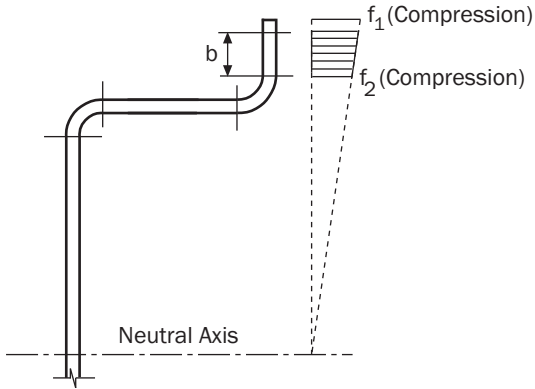

(b) Outward Facing Lip

Figure B3.2-1(b)

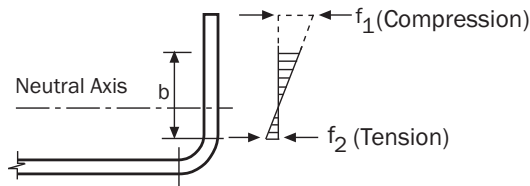

(a) Unsupported Edge in Compression

Figure B3.2-2 (a)

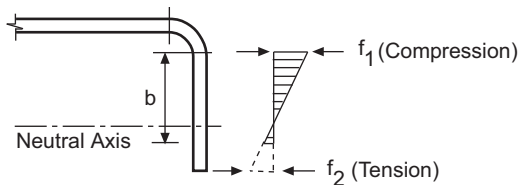

(b) Supported Edge in Compression

Figure B3.2-2(b)

B4 Effective Widths of Elements with a Simple Lip Edge Stiffener

For cold-formed steel beams such as hat or box sections, the compression flange is supported along both longitudinal edges by webs. In this case, if the webs are properly designed, they provide adequate stiffening for the compression elements by preventing their longitudinal edges from out-of-plane displacements. On the other hand, in many cases only one longitudinal edge is stiffened by the web, while the other edge is supported by an edge stiffener. In most cases, the edge stiffener takes the form of a simple lip, such as in the C-section and I-section.

The following notation is used in this section.

| | | |
|-----------|---------------------------------------|------------|
| S | $= 1.28\sqrt{E/f}$ | (Eq. B4-7) |
| k | $=$ Plate buckling coefficient | |
| d, w, D | $=$ Dimensions defined in Figure B4-1 | |

- d_s = Reduced effective width of stiffener as specified in this section. d_s is to be used in computing overall effective section properties (see Figure B4-1)
- d'_s = Effective width of stiffener calculated according to Section B3.2 (see Figure B4-1)
- A_s = Reduced area of stiffener as specified in this section. A_s is to be used in computing overall effective section properties. The centroid of the stiffener is to be considered located at the centroid of the full area of the stiffener.
- I_a = Adequate moment of inertia of stiffener, so that each component element will behave as a stiffened element.
- I_s = Moment of inertia of full section of stiffener about its own centroidal axis parallel to element to be stiffened, and effective area of stiffener, respectively. For edge stiffeners, the round corner between stiffener and element to be stiffened shall not be considered as a part of the stiffener.

For the stiffener shown in Figure B4-1:

$$I_s = (d^3 t \sin^2 \theta) / 12 \quad (\text{Eq. B4-10})$$

B4.2 Uniformly Compressed Elements with an Edge Stiffener

An edge stiffener (Figure B4-1) is used to provide a continuous support along a longitudinal edge of the compression flange to improve the buckling stress in the flange. Even though in most cases, the edge stiffener takes the form of a simple lip, other types of edge stiffeners can also be used for cold-formed steel members.

In order to provide necessary support for the compression element, the edge stiffener must possess sufficient rigidity. Otherwise it may buckle perpendicular to the plane of the element to be stiffened.

Section B4 in the Specification recognizes that the necessary stiffener rigidity depends upon:

- Slenderness (w/t) of the plate element being stiffened. The interaction of the plate elements, as well as the degree of edge support, full or partial, is compensated for in the expressions for k , d_s , and A_s .
- For $w/t > S/3$, the equation for $k_a = 5.25 - 5(D/w) \leq 4.0$ is applicable only for simple lip stiffeners because the term D/w is meaningless for other types of edge stiffeners.

(a) *Strength Determination*

For $w/t \leq 0.328S$:

$$I_a = 0 \quad (\text{no edge stiffener needed})$$

$$b = w \quad (\text{Eq. B4-1})$$

$$b_1 = b_2 = w/2 \quad (\text{see Fig. B4-1}) \quad (\text{Eq. B4-2})$$

$$d_s = d'_s \quad \text{for simple lip stiffener} \quad (\text{Eq. B4-3})$$

For $w/t > 0.328S$

$$b_1 = b/2 (R_I) \quad (\text{see Fig. B4-1}) \quad (\text{Eq. B4-4})$$

$$b_2 = b - b_1 \quad (\text{see Fig. B4-1}) \quad (\text{Eq. B4-5})$$

$$d_s = d'_s (R_I) \quad (\text{Eq. B4-6})$$

where

$$S = 1.28\sqrt{E/f}$$

I_a = Adequate moment of inertia of stiffener, so that each component element will behave as a stiffened element

$$I_a = 399t^4 \left[\frac{w/t}{S} - 0.328 \right]^3 \leq t^4 \left[115 \frac{w/t}{S} + 5 \right] \quad (\text{Eq. B4.2-8})$$

$$(R_I) = I_s/I_a \leq 1 \quad (\text{Eq. B4.2-9})$$

$$I_s = (d^3t \sin^2\theta)/12 \quad (\text{Eq. B4-10})$$

The effective width, b , shall be calculated in accordance with Section B2.1 with the plate buckling coefficient, k , as given in Table B4.1.

Table B4.1 Determination of Plate Buckling Coefficient k

| Simple Lip Edge Stiffener ($140^\circ \geq \theta \geq 40^\circ$) | |
|---|--|
| $D/w \leq 0.25$ | $0.25 < D/w \leq 0.8$ |
| $3.57(R_I)^n + 0.43 \leq 4$ | $(4.82 - \frac{5D}{w})(R_I)^n + 0.43 \leq 4$ |

where

$$n = \left[0.582 - \frac{w/t}{4S} \right] \geq \frac{1}{3} \quad (\text{Eq. B4.2-11})$$

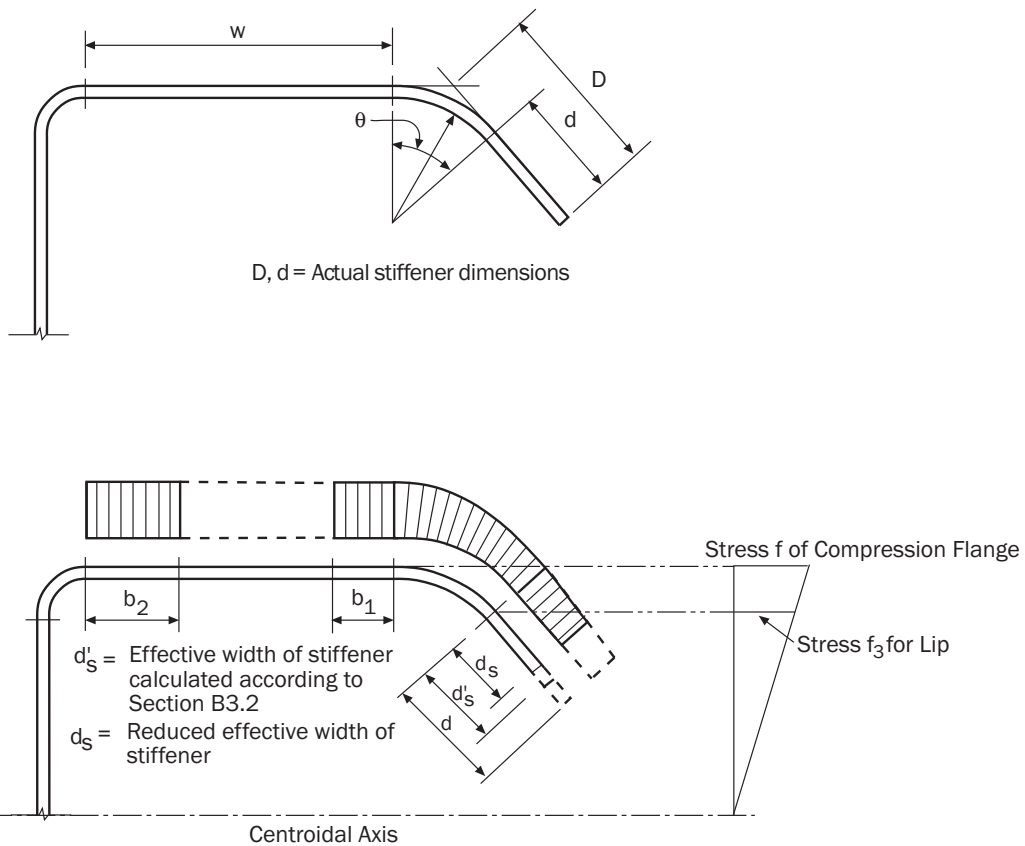

Figure B4-2 Elements with Simple Lip Edge Stiffener

(b) *Serviceability Determination*

The effective width, b_d , used in determining serviceability shall be calculated as in Section B4(a), except that f_d is substituted for f where f_d is computed compressive stress in the effective section at the load for which serviceability is determined.