

Improvement to AISI Section B5.1.1 for Effective Width of Elements with Intermediate Stiffeners

B.W. Schafer

This brief note discusses a change to the effective width determination for elements with intermediate stiffeners (e.g., the compression flange of deck sections) in local buckling. Current provisions (Section B5.1.1 of AISI-S100-07) can lead to erroneously conservative solutions, particularly for sections with a single stiffener located at mid-width of the element. The problem is easily rectified by using the more general expressions for local buckling already available in Specification section B5.1.2. A ballot has been proposed to remedy the problem.

The AISI Specification provisions for determining the effective width of elements with intermediate stiffeners have undergone significant revisions in recent editions. In 2001 entirely new provisions were adopted for stiffened and edge stiffened elements with multiple intermediate stiffeners based on the work of Schafer and Peköz (1998). In 2007 the provisions for single intermediate stiffeners were removed and the 2001 multiple intermediate stiffener provisions expanded to cover both single and multiple intermediate stiffeners in stiffened and edge stiffened elements based on the work of Yang and Schafer (2006).

The basic basis of the current intermediate stiffener provisions is the determination of (a) plate sub-element local buckling, and (b) distortional buckling of the intermediately stiffened element as illustrated in the AISI commentary, reprinted here as Fig. 1. Once the plate buckling coefficient (i.e., the “k” value) is determined for each of the modes, the smaller of the two is selected for effective width determination.

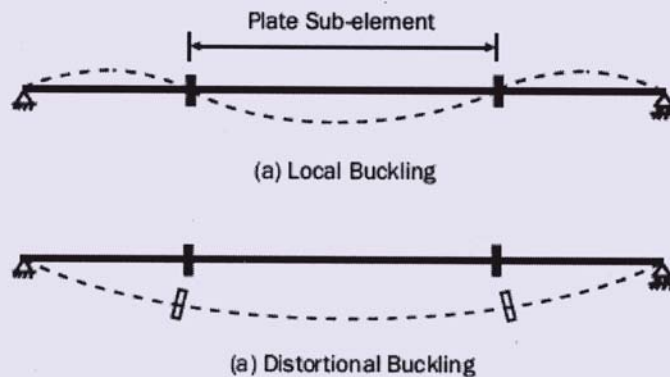
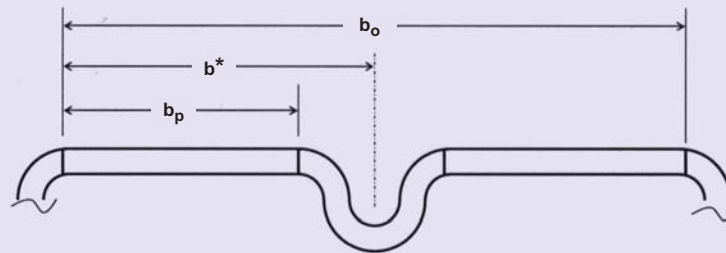

Figure C-B5.1-1 Local and Distortional Buckling of a Uniformly Compressed Element with Multiple Intermediate Stiffeners

Fig. 1

The focus of the discussion here is plate sub-element local buckling. As Fig. 1 shows, the “thinking model” behind the determination of the local buckling mode is essentially that of an intermediate stiffener of zero width. However, in actual elements, as shown in Fig. 2, the local buckling of the plate sub-element would occur in the element flat, i.e. over a width of b_p .



(a) element with real stiffener

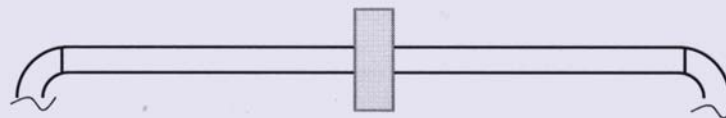

Fig. 2

The local buckling stress (F_{cr}) for the plate sub-element, b_p , is:

$$F_{cr} = 4 \frac{\pi^2 E}{12(1-\mu^2)} \left(\frac{t}{b_p} \right)^2 \quad (1)$$

where the plate buckling coefficient is 4, E is the modulus of elasticity, μ is Poisson's ratio, and t is the element thickness. In the Specification, the local buckling stresses (local and distortional) are written in terms of the full flat width, b_o , i.e.:

$$F_{cr} = k \frac{\pi^2 E}{12(1-\mu^2)} \left(\frac{t}{b_o} \right)^2 \quad (2)$$

Of course, the two buckling stresses are the same for local buckling, so setting Eq. 1 equal to Eq. 2 and solving for k one finds:

$$k = 4(b_o / b_p)^2 \quad (3)$$

Eq. 3 is identical to Specification expression B5.1.2-1. For intermediate stiffeners that are not equally spaced, b_p is simply the largest flat width between stiffeners. This provides a general method for plate sub-element local buckling.

For the case of equally spaced stiffeners the Specification currently uses the simpler “model” of Fig. 1 and ignores the stiffener width – which is equivalent to using b^* of Fig. 2 instead of b_p , which results in:

$$k = 4(b_o / b^*)^2 = 4(b_o / \frac{b_o}{n+1})^2 = 4(n+1)^2 \quad (4)$$

where n is the number of stiffeners. Eq. 4 is identical to Specification expression B5.1.1-1. On the surface the change (from b_p to b^*) seems relatively small. For elements with multiple intermediate stiffeners local buckling almost never controls, and as a result the conservative simplification of Eq. 4 rarely results in any change to the actual capacity.

However, in the 2007 AISI Specification when the B5.1.1 provisions were extended to single stiffeners the difference between Eq. (3) and Eq. (4) became more important because local buckling is a more prevalent failure mode.

As an example consider the hat section fully detailed in Yang and Schafer (2006) as shown in Fig. 3.

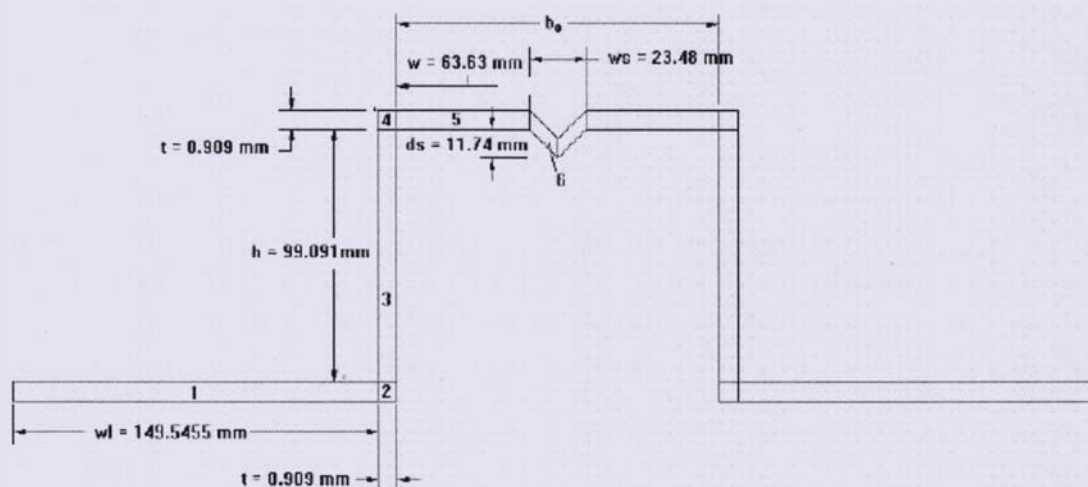

Fig. 3

For the intermediately stiffened element (compression flange of the section in Fig. 3) $b_o = 150.74$ mm and $b_p = 63.63$ mm; substitution into Eq. 3 results in a k of 22.4. Alternatively, $n=1$ for this same element and substitution into Eq. 4 provides a k of 16 – a difference of 40%. For either k in this section local buckling controls (the distortional buckling k is higher) and plate sub-element local buckling determines the effective width of the intermediately stiffened element. After the resulting effective width is calculated, and the effective bending modulus of the section as a whole determined, the difference between the use of Eq. 4 and Eq. 3 is approximately 13% in bending capacity.

All of the expressions in Specification Section B5.1.2 should simplify to those in Section B5.1.1; indeed the local buckling expression (Eq. 3 vs. Eq. 4) is the only one that does not. Further, since Eq. (3) is general, and its implementation no more cumbersome than Eq. (4), it has been proposed that Eq. 3 replace Eq. 4 in Section B5.1.1 of the AISI Specification.

Acknowledgments

The importance of this issue was brought to the attention of the writer by Barry Mandelzys, Manager of Engineering, Vicwest, Oakville, Ontario.

References

- Schafer, B. W., and Pekoz, T. (1998). "Cold-formed steel members with multiple longitudinal intermediate stiffeners." *Journal of Structural Engineering*, 124(10), 1175-1181.
- Yang, H., and Schafer, B. W. (2006). "Comparison of AISI Specification Methods for Members with Single Intermediate Longitudinal Stiffeners." American Iron and Steel Institute, Washington, D.C.